

# GRANT SECURITY SYSTEM MODEL 2001

## INSTALLATION/OPERATION INSTRUCTIONS

UNIT IDENTIFICATION NO.

LOCATED ON BOTTOM OF BASE UNIT

### NOTES

1. Before starting installation, read through all the cautions, notes, definitions and supplements, including those of the installation kit, steering wheel and this "Security System." Due to the variety of vehicles and type of Grant wheel being used, it is necessary to go from one instruction sheet to another. By reading through the literature first, you can become more familiar with the steps and terminology.
2. **IMPORTANT** Enclosed you will find an owner registration/service reply form. Please take the time to fill out and return it to us in the self-addressed envelope provided. Since this is a security item, **we must have this form on file should you ever need replacement keys or parts. The unit identification number contains the key code for your specific unit.**

### DEFINITIONS

- **Grant Classic and Challenger Steering Wheels** are the traditional Grant line including wood, vinyl, and foam rims with the standard three (3) hole mounting pattern and 3" diameter metal horn button.



CLASSIC TYPE



CHALLENGER TYPE



SIGNATURE TYPE

- **Grant Signature Steering Wheels** are of the European design, having wood, stitched vinyl, or leather rims and five (5) bolt mounting adapter collar and plastic horn button.
- **Installation Kit** — This is the Grant Kit specifically designed to adapt the Grant Anti-theft device and Grant Steering Wheel to your vehicle. Each kit includes: an adapter hub, column (post) cover, horn connections, turn signal canceling provision and necessary hardware.

- This unit must be installed only in conjunction with a Grant Installation Kit specifically designed for your vehicle and the Grant Steering Wheel of your choice: **Classic, Challenger or Signature.**
- Always have key in unlocked position before attempting to release the anti-theft unit.

### CAUTIONS

- **When Steering Wheel is removed from column, we do not recommend leaving wheel in view inside the car.** A would-be thief may just decide to steal your wheel out of spite. *We do recommend that you (1) slide wheel under your seat; (2) lock it in the trunk; or (3) take it with you.*
- Always lock unit and remove key after installing the Steering Wheel or lock-out cap. (The key can only be removed in the locked position and will not lock unless the mechanism is fully engaged.)
- **IMPORTANT** This Security Device has been partially assembled at the factory prior to shipping. To install, it is necessary to remove some hardware and partially disassemble the unit as instructed. **Do not remove any hardware or parts unless indicated to do so in this instruction sheet.**

## SPECIFICATIONS

- Torque specifications for the Grant Installation Kit, Grant Anti-theft Device, and Grant Steering Wheels as applied to the various bolt sizes. Do not overtighten screws as damage to hub or casting may result.

### TORQUE TABLE

① Steering Shaft Nut	25-30 ft. lbs.
② ¼ x 28 Shoulder Screw	10-12 ft. lbs.
③ ¼ x 28 Cap Screw	10-12 ft. lbs.
④ 8 – 32 Hex Drive Cap Screw	10-12 in. lbs.

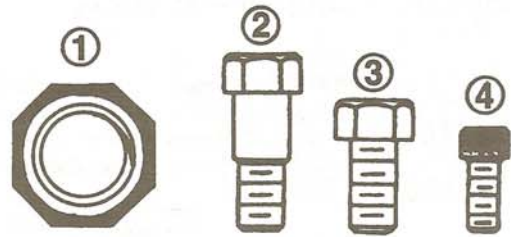

## INSTALLATION LAYOUT

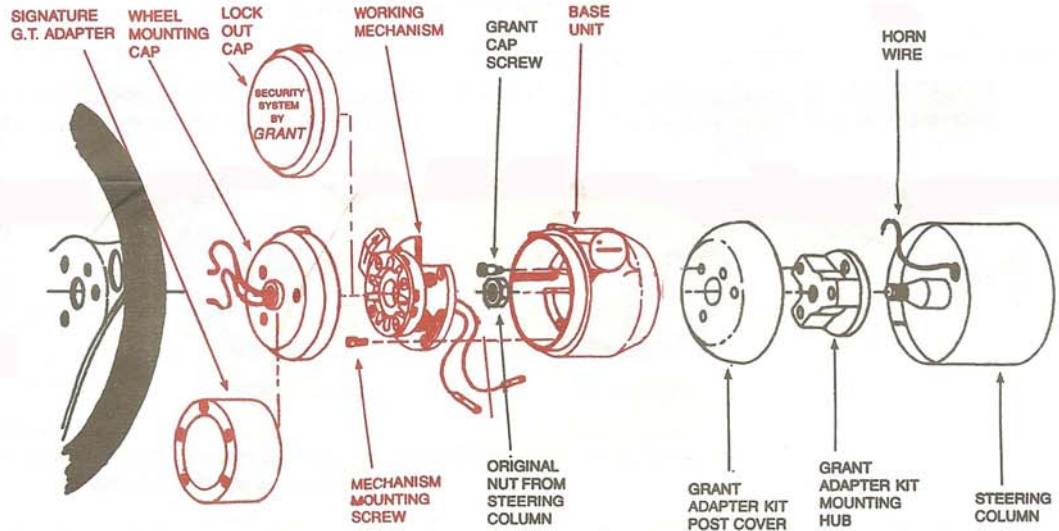

## INSTALLATION PREPARATION

The "Grant Security System" is packaged with the "Lock Out Cap" locked onto the base unit. The "Steering Wheel Mounting Cap" is packaged with the "Signature G.T. Wheel Adapter" bolted in place with three (3) 1/4 X 28 cap screws. These screws are installed at the factory to the proper torque specifications, and *need not be removed if you are installing the "Grant Signature G.T." Steering Wheel*. Complete Signature G.T. mounting steps are described in later instructions.

If your installation uses a "Grant Classic or Challenger" steering wheel, remove the three (3) 1/4 x 28 cap screws and the "Signature G.T. adapter" from the wheel mounting cap. Save the adapter for possible future use to install a "Signature" wheel. Set aside the three (3) 1/4 x 28 cap screws for use in mounting the base unit.

**To open the system:** Place the key into the lock and turn the key clockwise to the stop. Hold the base unit in one hand, rotate the release knob downward. With your other hand, grasp the "Lock Out Cap" and rotate it counterclockwise and remove.

The working mechanism is now exposed. Study this for a moment to become familiar with the operating principles of the unit. Rotate the release knob, noting how the locking plate moves from the locked to the release position. Rotate the key from the unlocked to the locked position, noting how the bolt secures, and prevents the locking plate from being released. *Be sure that the key is in the unlocked position before proceeding further.*

With the hex-type wrench supplied, remove the four (4) 8-32 hex drive screws located in the base of the working mechanism within the base unit. Lift the working mechanism from the base unit and set all of the components aside. The "Security System" is now prepared for installation.

**NOTE: DO NOT REMOVE ANY HARDWARE OR PARTS UNLESS INDICATED TO DO SO IN THIS INSTRUCTION SHEET.**

**DO NOT TAMPER WITH THESE 4 TORX SCREWS**

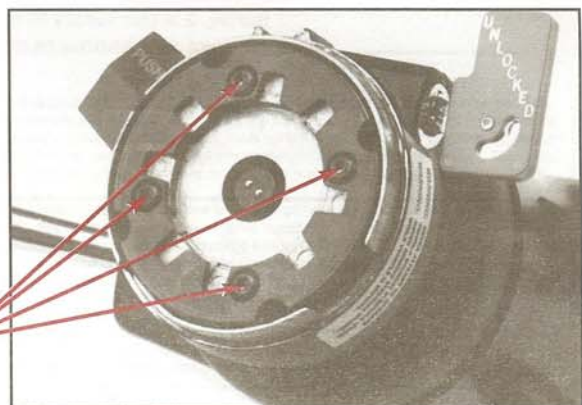

# STEP-BY-STEP INSTALLATION INSTRUCTION

- NOTE:**
1. If installing the "Security System" Installation Kit and Grant Steering Wheel, proceed to Step #1.
  2. If installing the "Security System" in conjunction with an existing Grant Steering Wheel and installation kit, remove the existing horn button, steering wheel and hardware, then proceed to Step #2.

- 1 Follow the installation kit instructions for your vehicle through the conclusion of the step: "Installing the hub onto the column." At the conclusion of this step, refer back to this form, beginning with Step #2 below.

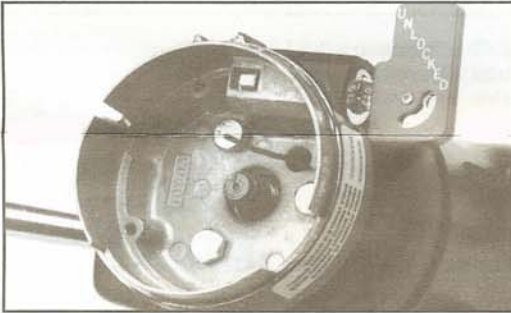

- 2 ■ Position post cover and the "Security System" base unit onto the hub, threading the lead wire(s) thru as required. If installing the "Grant Classic" or "Challenger" steering wheel, use the three (3) 1/4 x 28 cap screws previously removed from the "Signature Adapter."

■ If installing a "Signature" wheel, use the three (3) 1/4 x 28 cap screws supplied with the wheel (do not use the shoulder bolts) to secure the base unit and post cover to the hub.

■ Check to see if this assembly is in the proper position (as shown above), and if correct, install the wheel retainer nut (or bolt) onto shaft. Tighten the retaining nut (or bolt) and the three (3) cap screws to the proper torque requirements, per the torque table

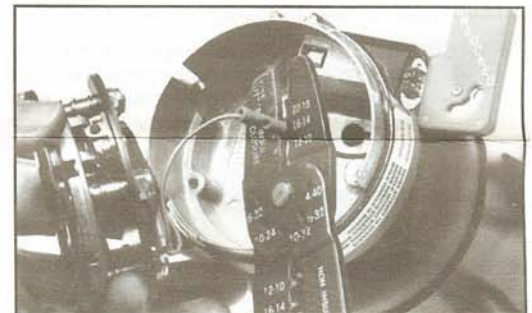

- 3 ■ The working mechanism will now be reinstalled into the base unit, beginning with the connection of the wire lead(s) as follows:

- **For one (1) wire system** — Attach the wire coming from Grant hub or column to the red wire lead extending from bottom of working mechanism (do not use black wire at all). Do this by cutting wire and stripping insulation back about 3/8", insert wire into butt connector on end of wire and crimp securely with pliers or crimping tool. You can either cut black wire off or just coil it up with the others..

- **For two (2) wire systems (many Ford vehicles)** — Install as above for each wire. Connect one lead to red wire and the other to black wire.

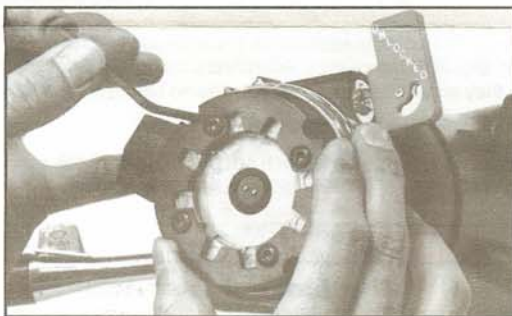

- 4 ■ **Note:** Due to minimal clearances between mechanism and base unit sidewall, position four (4) 8-32 hex drive screws through holes in mechanism before lowering into base unit.

Coil the wire lead(s) into center area and carefully lower mechanism into base unit taking care not to pinch any wires. Once mechanism bottoms, check that it is sitting completely flat in base unit. If not, a wire is pinched and must be repositioned. Once mechanism is seated correctly, tighten the four (4) 8-32 hex drive screws with wrench supplied to 10-12 inch lbs. of torque. Do not overtighten as damage to casting may result.

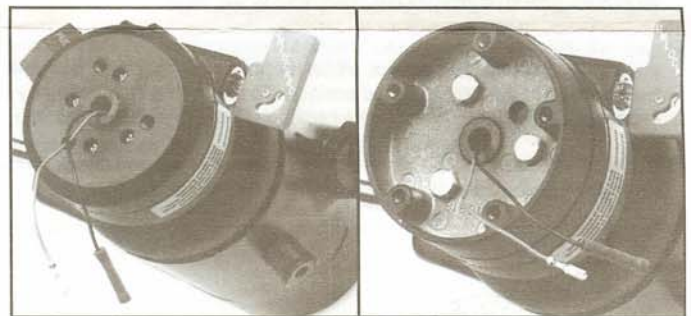

Shown prepared for Classic or Challenger wheel

Shown prepared for Signature wheel

- 5 ■ Install the "Wheel Mounting Cap" on the mechanism; apply downward pressure on the cap and rotate clockwise until the mechanism engages.

(Alignment bosses will be in line and you should hear a distinct "click" when engaged.)

**NOTE:** For installation of the "Grant Classic" or "Challenger" continue with Step #6. For installation of the "Grant Signature", go to step #7.

**6** ■ Thread the wire leads, from the "Wheel Mounting Cap," thru the center hole in the steering wheel and align the wheel using the three (3) ¼ x 28 shoulder bolts supplied with the installation kit and proceed with the installation kit instructions for your particular application, beginning with the step listed below. (Delete the instruction for installing the center nut on the wheel, and for (1) wire lead applications use the red wire lead only. The wire lead(s) must be threaded thru the side of the coil spring.

**SPECIFICATIONS** See torque specifications for this vehicle make as applied to the various bolt sizes. Do

TORQUE TABLE	
① Steering Shaft Nut	25-
② ¼ x 28 Shoulder Screw	10-
③ ¼ x 28 Cap Screw	10-
④ 8 - 32 Hex Drive Cap Screw	10-

**INSTALLATION LAYOUT**

SIGNATURE G.T. ADAPTER WHEEL MOUNTING CAP LOCK OUT CAP WORN MECH



**NEXT:** ■ Depending what form # instruction sheet your installation kit uses, proceed with the next step as listed below.

CLASSIC		CHALLENGER	
FORM #	BEGIN WITH STEP #	FORM #	BEGIN WITH STEP #
2	9	8	12
3	11	9	16

**7** ■ To install the "Grant Signature" Steering Wheel the following will apply: The "Signature G.T." Steering Wheel comes packaged with an adapter collar, covered with a rubber boot. This collar and boot must be removed. You will not need them for installing wheel onto Security Device. Remove the five (5) hex drive screws attaching the wheel to the collar.

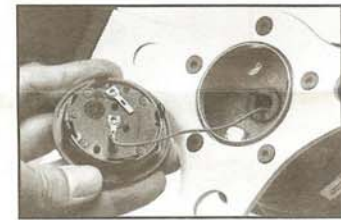

- Transfer the wheel, horn button retainer ring, and/or trim ring,...etc. to the "Wheel Mounting Cap" using the "Signature G.T." adapter supplied with Security System. Tighten the five (5) hex drive screws to the proper torque requirements, per the torque table.
- For one (1) wire installations: attach the red wire lead to center spade connector on the plastic G.T. horn button.
- For two (2) wire installations: attach one (1) wire to each spade connector on the horn button. (After cutting grounding spring as explained on sheet provided with steering wheel).
- Snap the horn button into the wheel, reconnect the battery and check the operation of the horn.

**SIGNATURE**

### DESIGN CHARACTERISTIC

■ With steering column in the locked position, you will notice when forced, a very slight rotational movement between wheel and base. You can visually see this by referencing the alignment bosses. This movement is normal rubber dampener tolerance, which is an inherent design characteristic of engagement devices of this type. This should not be noticeable during normal driving conditions.

### TROUBLE SHOOTING

- **Locking plate will not release.** First check that unit is unlocked with key (warning flag) indicating unlocked. Next, check that the release knob, when rotated, is turning the axle connected to it; if not, check and tighten the two (2) set screws located on the top and back of the knob and try to release again.
- **Horn will not blow.** First, check that the contactor probes (located on the base unit) have not been damaged. Next, check all wire connectors on the wheel as well as tracing all wire connections back to the column.
- **Key will not release from lock.** This unit is designed so that the key can only be removed in the fully locked position. If the locking plate is not fully engaged, the dead bolt cannot fully extend, which will prevent the key from being released from the lock. If this should occur, it means the wheel or lockout cap has not been rotated to the fully engaged position. To check this, reference alignment bosses; they should be in line and you should hear a distinct click when unit engages. Do not force key to locked position or damage to lock cylinder may result.
- **Unusual vibration or looseness.** First, remove wheel and check (4) mechanism mounting screws with wrench supplied. Next, check screws securing wheel to mounting cap. If vibration or looseness still exists, then remove mechanism and check hardware securing base unit to column.



**GRANT PRODUCTS**  
1770 Evergreen St.  
Duarte, California 91010

**Our Limited Warranty**

We warrant this product for ninety (90) days from the date of original purchase to be free from defects in materials and workmanship. If, during this period, the product fails under normal usage because of a manufacturing defect, then we will replace or repair the item. To obtain repair or replacement under the terms of this warranty, notify us at 615 Elca Lane, Suite C, Brownsville, TX 75821. Proof of purchase and date of purchase are required to validate warranty.

All implied warranties, including warranty of merchantability, are limited to this same ninety-day period from date of original purchase. We are not liable for any direct or consequential loss or property damage arising from any use of this product. This warranty gives you specific legal rights, and you may also have other rights which vary from state to state. Offer good in U.S.A. and Canada only.

**IMPORTANT**

FOR YOUR OWN SAFETY, DO NOT USE THIS WHEEL FOR ANY COMPETITIVE OR COMMERCIAL RACING PURPOSES: RACING DOES NOT CONSTITUTE NORMAL USAGE AND THEREFORE MAKES THIS WARRANTY VOID.